



SM16R Modem Rack Installation and Operation Guide

Table of Contents

CHAPTER 1 INTRODUCTION	5
OVERVIEW.....	5
BACK PANEL INTERFACE CONNECTORS	6
CONTACT INFORMATION	7
CHAPTER 2 INSTALLATION	9
UNPACKING AND INSPECTING THE EQUIPMENT	9
SITE PREPARATION.....	9
INSTALLATION PROCEDURES.....	11
<i>Required Tools and Equipment</i>	11
<i>Mechanical Assembly</i>	11
ELECTRICAL INSTALLATION	12
<i>AC Power (SM16R ACV-R Modem Rack)</i>	12
<i>DC Power (SM16R DCV-R Modem Rack)</i>	12
<i>Digital EIA-232 Interface</i>	13
TELEPHONE LINE INTERFACES	14
<i>Modular Jack Connectors</i>	14
<i>Optional Backplanes for Dial Backup Connections</i>	14
INSTALLING AND REMOVING POWER MODULES.....	14
<i>AC Power Module</i>	14
<i>DC Power Module</i>	16
<i>Installing Power Modules</i>	16
<i>Removing Power Modules</i>	16
INSTALLING AND REMOVING PC CARDS	17
<i>Removing PC Cards</i>	17
DIGITAL INTERFACE BACKPLANE INSTALLATION.....	18
CHAPTER 3 OPERATION	21
TEST MODES	21
FRONT PANEL INDICATORS	21
CHAPTER 4 MAINTENANCE	22
PC CARDS	22
POWER MODULE	22
APPENDIX A SPECIFICATIONS	23
APPENDIX B DIGITAL INTERFACE DESCRIPTIONS	24
APPENDIX C TELEPHONE LINE CABLES	27
TECHNICAL SUPPORT	33
RETURN MERCHANDISE AUTHORIZATION (RMA) PROCEDURE	31

Chapter 1

Introduction

The Synxcom SM16R Modem Rack is a heavy-gauge steel-plated modem rack chassis. It measures 7 inches high and 10.75 inches deep, and mounts in a standard 19- or 23-inch rack. The Modem Rack comes in two versions: AC (SM16R-227) and DC (SM16R-233). This Guide covers both versions.

Overview

The Synxcom SM16R Modem Rack has slots that accept 16 leased line modems:

All of these devices are plug-in printed circuit (PC) cards that slide into the front of the Modem Rack. The cards can be mixed in any way within the Modem Rack. Each card has been independently tested and meets Part 68, FCC rules and regulations.

Power, Data Terminal Equipment (DTE), and communication-line connections are made at the back panel of the Modem Rack (see “Back Panel Interface Connectors” on page 6). This allows PC cards to be installed or replaced, without disturbing the cable connections at the back.

The AC version of the Modem Rack accepts a single power module that occupies two slots, while the DC version accepts two power modules that occupy one slot each. The power modules power all the PC cards in the Modem Rack, converting user-supplied 48 volt DC input to +15 Vdc, -15 Vdc, and +8.5 Vdc outputs for distribution to the PC cards. Regulators on the PC cards convert the plus and minus 15 Vdc to plus and minus 12 Vdc and +8.5 Vdc to +5 Vdc.

NOTE: If two power modules are installed in the DC version of the Modem Rack, one powers the Modem Rack while the other acts as a redundant power source.

Figure 1-1 shows an example of the location and orientation of the modem cards and power module. For convenience, the front panel of the Modem Rack is hinged to allow easy access to the modem cards and power module(s) without disturbing the DTE and communication-line connections at the back of the Modem Rack.

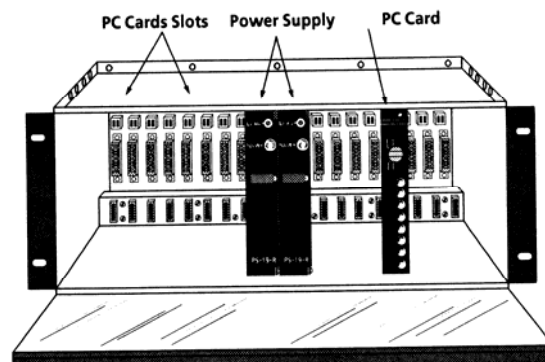

Figure 1-1. Modem Rack Example

Operation

Back Panel Interface Connectors

All DTE, Telco and power connections are made at the back panel of the Modem Rack .

The DTE connectors can be:

- ❖ Individual 25-pin connectors — one for each PC card (standard)
- ❖ Two 50-pin mass termination connectors (optional)

The Telco connectors can be:

- ❖ Individual 8-pin modular jacks — one for each PC card (standard)
- ❖ Two 50-pin termination connectors (optional)

The telephone-line connectors are identified by the telephone company Universal Service Ordering Code (USOC) and must be specified when ordering standard jack arrangements from Synxcom.

The various jack arrangements ensure that the signal level received at the telephone company central office does not exceed – 12 dBm. The Modem Rack has been registered with the FCC per the requirements of Part 68 of the FCC rules for:

1. Programmable Mode — the local telephone company will install a resistor internal to the jack (USOC RJ455 or RJ41S).
2. Permissive Mode — the individual modem cards are preprogrammed for a maximum transmit level of –9 dBm (USOC RJ11C or RJ16X).

Figures 1-3 through 1-5 show examples of Modem Rack back panels.

NOTE: For more information about the power connections, refer to “Electrical Installation” on page 12.

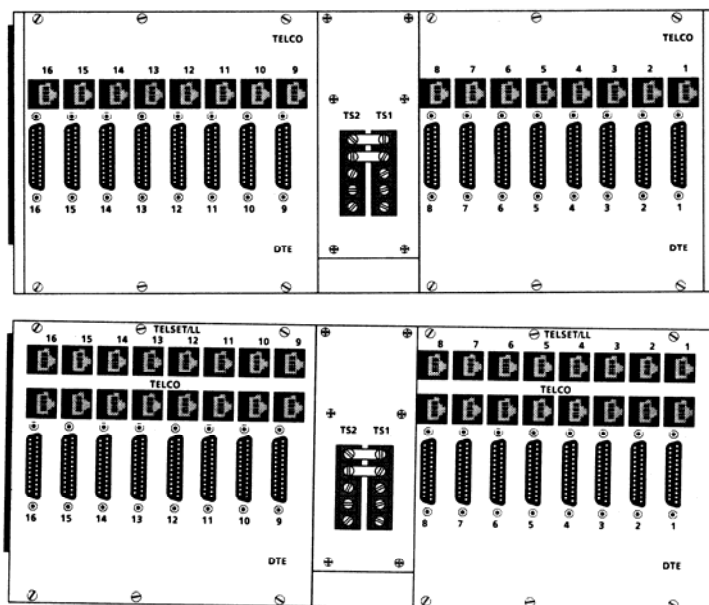

Figure 1-3. Examples of Back Panels with 25-pin DTE Connectors and 8-pin Modular Telco Jacks

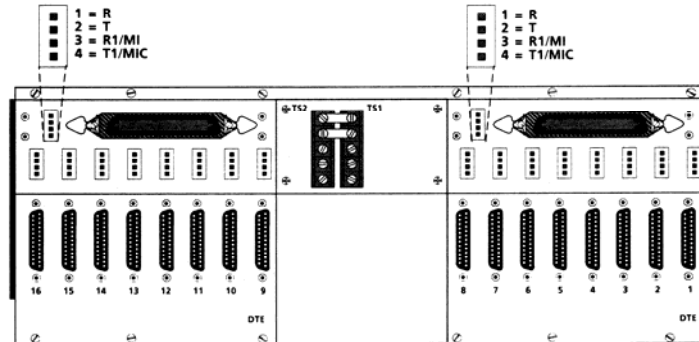

Figure 1-4. Example of Back Panel with 25-pin EIA DTE Connectors and Mass Termination Telco Connectors

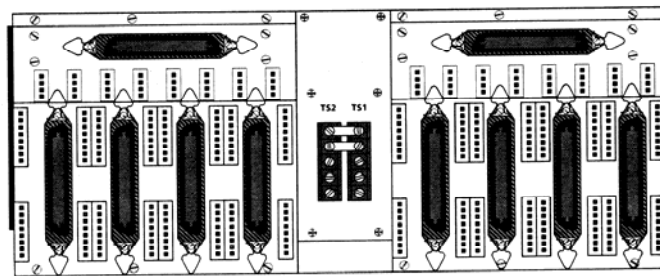

Figure 1-5. Example of Back Panel with Mass Termination Connectors for DTE and Telco Connections only)

Contact Information

For more information about Synxcom Modem Rack, or other Synxcom solutions, contact us using any of the following methods.



Voice Calls

We welcome your calls at **(949) 667-6204** Monday through Friday, from 8:00 am to 5:00 pm Pacific Time.



Fax Number

You can also send your requests for information to our 24-hour fax number: **(949) 872-2889**.

Operation



E-mail

If you prefer, you can send information requests to our 24-hour e-mail address: **sales@Synxcom.com**.



Website

Our website contains valuable information about our products. We encourage you to visit us online at **www.Synxcom.com**.

Chapter 2

Installation

This chapter describes how to install the Modem Rack .

Unpacking and Inspecting the Equipment

Unpack the equipment and compare the contents to the packing list. Inspect the equipment for any damage that may have occurred in shipment. If you see any damage or if items are missing, contact Synxcom. Keep the shipping container and packing material for future shipment.

Site Preparation

When selecting a location to install the Modem Rack , choose a site that:

- ❖ Is clean, well lit, and free from extremes of temperature, humidity, appreciable shock, and vibration.
- ❖ Is within seven feet of a power source that can furnish 48 ± 4 Vdc at 3.5 amps.
- ❖ Is within 50 feet of the associated data terminal.
- ❖ Provides at least 36 inches of clearance at the front for operating and maintenance accessibility.
- ❖ Provides at least 4 inches at the back of the enclosure for interface cable clearance and unobstructed airflow.

Side and top clearances for rack-mounted equipment are dictated by the rack-cabinet provisions, but should allow a free flow of cooling air (Figure 2-1).

Operation

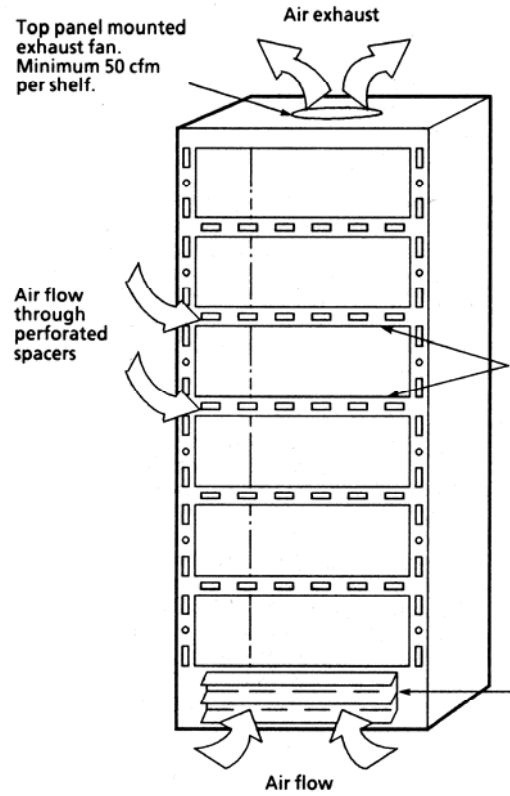

Figure 2-1. Modem Rack Cabinet

Installation Procedures

Service personnel should be familiar with the complete installation procedure before installing the shelf.

Required Tools and Equipment

Special tools or test equipment are not required for installation.

CAUTION: To prevent damage to enclosure components from overheating, ensure clearances of 1 $\frac{3}{4}$ -inch top and bottom between mounted enclosures. Make adequate provision for cool air circulation and exhaust of warm air, such as air intake louvers in the bottom panel of the Modem Rack cabinet and an adequate CFM exhaust fan in the top panel of the Modem Rack cabinet.

Mechanical Assembly

The Modem Rack mounts into a standard 19-inch cabinet and requires 7 inches of vertical panel space (see Figure 2-2).

The 19-inch Modem Rack also fits into a 23-inch cabinet. This installation requires the rack-mounting brackets to be removed and reinstalled in the reversed position, so the wider tabs are used for mounting to the cabinet (see Figure 2-3).

Operation

Electrical Installation

All power connections are made at the back panel of the Modem Rack .

AC Power (SM16R ACV-R Modem Rack)

Power for the AC version of the Modem Rack(SM16R ACV) is supplied to the power modules through a separate AC power cord. The power cord is fastened to the back panel with a cable clamp to prevent it from becoming unattached.

After the power module is installed and fastened to the rear panel, insert the power cord into the power module socket on the back of the Modem Rack .

To apply power to the module plug the opposite end of the power cord into a standard 115VAC grounded wall socket.

DC Power (SM16R DCV Modem Rack)

Power for the DC version of the Power Shelf (SM16R DC) is provided by an incoming power source that connects to TS1, TS2, or both on the back of the Data Panel (see Figure 2-4). Facing the front of the Modem Rack , TS1 supplies the power module on the left and TS2 supplies power to the power module on the right.

One power module is sufficient to power all 16 slots. If one power source is available, it can connect to either terminal strip (TS1 or TS2) on the back of the Modem Rack , with shunt bars installed to connect power to the opposite strip (see Figure 2-5). The bars should always be installed if only one power source is used and must be removed if two power sources are used.

TS1 and TS2 alarms and chassis ground are connected internally. An alarm condition exists on the alarm circuit when any operating or supply voltage is lost on either power supply. By observing which front panel power LED is out, you can identify the faulty power supply.

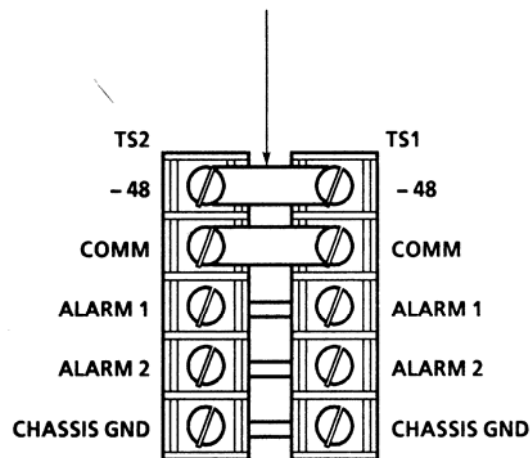

Figure 2-4. Power Terminals

Figure 2-5. Example of a Single Power Source Installation

Digital EIA-232 Interface

The 16 EIA-232C or D digital input connectors are labeled and shown in Figure 2-2. These connectors are either Cannon or Cinch 25-pin D series, as defined in EIA-232. For a description of the active pin connectors, refer to Appendix D on page 24.

Table 2-1 shows the EIA-232 levels from the modem.

NOTE: Some modems may not use all the functions listed in Tables 2-1 and 2-2.

Table 2-1. Modem EIA Levels

Received data mark:	-5 to -15 V
Received data space:	+5 to +15V
Control signal OFF level:	-5 to -15V
Control signal ON level:	+5 to +15V

Table 2-2 shows the expected levels on all inputs.

Table 2-2. Expected Levels on All Inputs

Mark:	-3 to -25 V
Space:	+3 to +25V
Controls OFF:	-3 to -25V
Controls ON:	+3 to +25V

Telephone Line Interfaces

The Modem Rack is FCC certified for connection to the dial-up Public Switched Telephone Network (PSTN). The following sections describe the standard and optional ways for connecting to the communications line.

Modular Jack Connectors

The standard Modem Rack back panel has 16 8-pin modular jacks, one for each modem. These jacks provide the interface for connecting individual modems to the telephone line. Each 8-pin jack has contacts that are used in various combinations depending on the type of service installed. Leased-line modems, by comparison, have four contacts: a transmit pair and a receive pair.

For a description of the modular jack functions, refer to Table E-1 in Appendix E on page 27.

Optional Backplanes for Dial Backup Connections

Two optional Modem Rack backplanes are available for use with dial backup modems. These backplanes provide either modular or mass termination jacks for both dial-up and leased line telephone line connections. Figure 1-4 on page 7 and Figure 1-5 on page 7 show examples of these backplanes.

Modems with dial backup capability can switch to a dial-up line if the leased line fails. For this reason both the TELSET/LL and TELCO connections must be made. If the option is not used, connect the modem to the appropriate service, either leased line or dial-up. If standard modems (no dial backup capability) are installed they are limited to connection to the TELCO only.

For a description of the modular jack functions, refer to Table E-1 in Appendix E on page 27.

NOTE: Telco jack pin functions are identical for both standard and dial backup modems. Similarly, DTE connectors are the same as for standard modems.

Installing and Removing Power Modules

Power modules generate power that is bused to the 16 modem edge connectors on the recessed power bus. Power modules are available in AC and DC versions.

AC Power Module

The AC power module is a 2-slot module designed for the SM16R ACV-R Modem Rack . The SM16R ACV Modem Rack can hold a maximum of one AC power module.

The AC power module consists of:

- ❖ Two transformers (one for slots 1 through 8 and the other for slots 9 through 16)
- ❖ Two push-button circuit breaker switches on the front panel
- ❖ A red 3.5 Amp light on the front panel
- ❖ A 115 or 230 VAC connector on the back of the module

Table 2-3 lists the connector pin functions on the AC power module.

Table 2-3. Power Connector Pin Functions

Pin Contact	Function
1 and A	Plus and minus 12 Volt Winding
2 and B	
3 and C	12 Volt Common
4 and D	5 Volt Winding
5 and E	
6 and F	Chassis Ground

Operation

DC Power Module

The DC power module is a single-slot module designed for the SM16R DC Modem Rack . The SM16R DC Modem Rack can hold up to two power modules. When two power supply modules are used, any loss of supply or operating voltage to one module causes the other module to carry the entire load. If this happens, the common alarm contacts close to reflect the alarm condition.

The DC power module consists of:

- ❖ A DC-to-DC switching regulator
- ❖ A green Power light on the front panel
- ❖ An interface connector on the back of the module

Installing Power Modules

The following procedures describe how to install power modules. This procedure should only be performed by personnel familiar with this procedure.

1. Lower the Modem Rack 's hinged front panel.
2. Locate the power module slots between slots 8 and 9.
3. Grasp power module handle with one hand while supporting the bottom of the module with your other hand.
4. Align the module in the Modem Rack guide grooves.
5. Gently slide the module into the Modem Rack until it rests against the edge connector.
6. Firmly push the module in to seat the edge connector.
7. To install a second DC power module, repeat steps 2 through 5, selecting the adjacent power module slot in step 2.
8. Close the front panel.
9. Tighten the holding screw on rear of housing.
10. When you finish, connect a power source to the module.
 - ❖ AC modules: connect a power cord to AC plug on rear of power module. Then plug power cord into a 115 or 230 VAC outlet, as required.
 - ❖ DC modules: attach a DC power source as described under “DC Power” on page 12
11. Raise the hinged front panel.

Removing Power Modules

To remove power modules:

1. Remove the power source from the back of the Modem Rack .
2. If there is a holding screw on rear of the housing, loosen the screw.
3. Lower the hinged front panel.
4. Grasp power module handle and gently slide it out through the front of the Modem Rack .

Installing and Removing PC Cards

PC cards have edge connectors that insert into receptacles located on the backplane and power bus. When installing the PC cards, equalize the loads on the power module. For example, if the shelf has nine cards, five should be loaded in one half of the Modem Rack(slots 1 through 8) and four should be loaded into the other half of the Modem Rack(slots 9 through 16).

Caution: Consult the printed circuit card manual to determine if hardware options need to be changed or verified before inserting the card.

The following procedures describe how to install PC cards. PC cards can be installed while the Modem Rack is powered on. This procedure should only be performed by personnel familiar with this procedure.

1. Lower the Modem Rack 's hinged front panel.
2. Orient the card so the component side is facing to the left.
3. Align the module in the Modem Rack guide grooves.
4. Gently slide the module into the Modem Rack until it rests against the edge connector.
5. Firmly push the card in to seat the edge connector.
6. To install additional PC cards, repeat steps 2 through 5.
7. When you finish, close the hinged front panel.

Removing PC Cards

PC cards can be removed while the Modem Rack is powered on. To remove PC cards:

1. Lower the Modem Rack 's hinged front panel.
2. Pull the card pullers on the PC module to slide the PC card out through the front of the Modem Rack(see Figure 2-5).
3. To remove additional PC cards, repeat step 2.
4. When you finish removing PC cards, raise the hinged front panel.

Operation

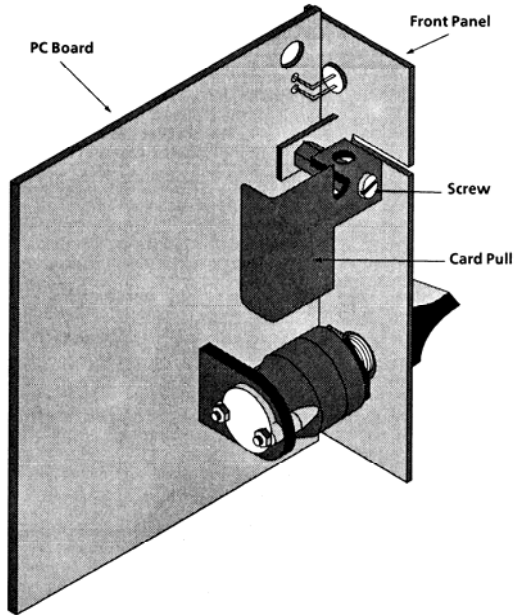

Figure 2-5. PC Card Module

Digital Interface Backplane Installation

When the digital interface backplane is required, use the following installation procedure:

- ❖ Determine which of the two EIA-232 connectors requires the special backplane. Each backplane converts two EIA-232 connectors to one 50-position connector or 50-wire wrap pins.
- ❖ Plug the two 25-pin male connectors into the two 25-pin receptacles.
- ❖ Insert the four screws (for J1 and J3 on the special backplane) and tighten.

P1 and P2 are
25-position terminal
strips with 0.045"
wire wrap pins.

J2 is a 50-position
miniature jack,
AMP P/N 552118-1
with bent bail
assembly,
P/N 552562-2

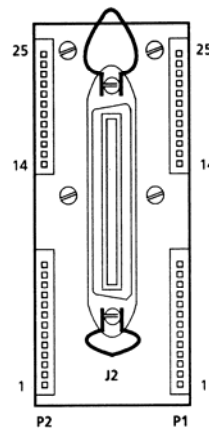

Figure 2-6. Digital Interface for the Optional Backplane

Table 2-4. Digital Interface Pin Functions, Special Backplane

J2	J1	J3	Wire Wrap
1	1		P1 1
26	2		2
2	3		3
27	4		4
3	5		5
28	6		6
4	7		7
29	8		8
5	9		9
30	10		10
6	11		11
31	12		12
7	13		13
32	14		14
8	15		15
33	16		16
9	17		17
34	18		18
10	19		19
35	20		20
11	21		21
36	22		22
12	23		23
37	24		24
13	25		25
38		1	P2 1
14		2	2
39		3	3
15		4	4
40		5	5
16		6	6
41		7	7
17		8	8
42		9	9
18		10	10
43		11	11
19		12	12
44		13	13
20		14	14
25		15	15
21		16	16
46		17	17
22		18	18
47		19	19
23		20	20
48		21	21
24		22	22
49		23	23
25		24	24
50		25	25

Chapter 3

Operation

The Modem Rack accepts leased line, PSTN, and DDS-type modems. Leased-line modems operate on conditioned or unconditioned leased lines. PSTN-type modems operate on the dial-up network and have features that allow establishment of dial-up circuits and data transfer. Some modems can operate on either leased lines or PSTN.

Modems designed for use in the Modem Rack have a standardized interface (EIA-232C or D) that provides for orderly calling, answering, and data modes. Many of the modems also have automatic dialing and answering capabilities.

Test Modes

Each plug-in modem card has a switch or switches that provide for modem testing. Test features are described in the manual for the modem.

Front Panel Indicators

Each PC card has Light Emitting Diode (LED) indicators that can be viewed through the transparent front panel. With the front panel lowered, the modem controls can be accessed.

Most modems have LEDs mounted on the front edge of the card to indicate the status of various EIA-232 interface functions. The LEDs are described in the manual for the modem.

Some PC cards have a Liquid Crystal Display (LCD) for observing modem status or selecting options using pushbuttons on the modem front panel. The LCD functions are explained in the manual for the modem.

Chapter 4

Maintenance

This appendix provides maintenance information for PC cards and power modules.

PC Cards

If a PC card becomes inoperative, replace it. Field repair is not recommended. Contact Synxcom for instructions on repairs and replacement (see “Contact Information” on page 7).

When swapping out PC cards, you do not have to turn off system power. This allows PC cards to be changed while allowing all other PC cards to continue operation.

For more information about installing and removing PC cards, refer to “Installing and Removing PC Cards” on page 17.

Power Module

The AC power module has two 115 VAC circuit breakers located on the module front panel. The left-hand breaker protects modem slots 1 through 8. The right-hand breaker protects modem slots 9 through 16.

The DC power module

For more information about installing and removing power modules, refer to “Installing and Removing Power Modules” on page 14.

Appendix A Specifications

EIA Standard:	Compliant with EIA Standard EIA-310-C	
Width:	19 inches (48.3 cm)	
Depth:	10.75 inches (27.3 cm)	
Height:	7 inches (17.8 cm)	
Weight:	20 lbs (9.1 Kg) shipped	50 lbs (22.7 Kg) loaded
AC Power (SM16R ACV-R):	Input voltage	115 VAC +/- 10%, 50/60 Hz
	Output voltage	30 +/- 10% VAC, 10 +/- 10% VAC, 50/60 Hz
	Wattage	150 watts per rack
DC Power (SM16R DCV-R):	Input voltages	48 volts DC +/- 5%
	Output voltages	15 volts DC +/- 10%
		-15 volts DC +/- 10%
		+9 volts DC +/- 10%
Heat Load	510 BTU/Hr (fully loaded rack).	
Environmental Conditions	Temperature (+32°F to 122°F) (0° to + 50°)	

Appendix B

Digital Interface Descriptions

This appendix lists the digital interface descriptions. The information in this appendix may vary, depending on modem type. Consult the manual for the particular PC card you are using.

Table B-1. Digital Interface Signal Descriptions (232-C)

Pin No.	EIA-232C	CCITT	Signal Name	Description
1	AA	101	Protective Ground or Earth Ground	Chassis ground. Isolated from signal ground or common return (pin 7).
2	BA	103	Transmit Data	Serial digital data (to be modulated) from a data terminal or other digital data source.
3	BB	104	Received Data	Serial digital data at the output of the modem receiver. Data is accompanied by an internal data rate clock (pin 17) whose positive-going transitions occur on the data transition. (Synchronous modems only.)
4	CA	105	Request to Send	A positive level to the modem when data transmission is desired.
5	CB	106	Clear to Send	A positive level from the modem after receipt of Request to Send (pin 4) and when the modem is ready to transmit.
6	CC	107	Data Set Ready	A positive level from the modem when power is on and it is ready to operate.
7	AB	102	Signal Ground or Common Return	Common signal and dc power ground. Isolated from protective ground (pin1).
8	CF	109	Received Line Signal Detector	A positive level from the modem indicating the presence of a receive signal (carrier detect).
9			+12 volts	+12 voltage reference
10			-12 volts	-12 voltage reference
11			Not used	
12	SCF		Sec. Received Line Signal Detector	Carrier detect on a secondary channel.
13	SCB	142	Sec. Clear to Send	Clear to send on a secondary channel.
14	SBA	141	Sec. Transmit Data	Transmitted data on a secondary channel.
15	DB		Transmit Clock (DCE)	A transmit data clock output for use by an external data source. Positive clock transitions correspond to data transitions.

Table B-1. Digital Interface Signal Descriptions (232-C)

Pin No.	EIA-232C	CCITT	Signal Name	Description
16	SSB		Sec. Rec'd Data	Received data on a secondary channel.
17	DD	115	Receive Clock	A receive data rate clock output for use by the external data sink. Positive clock transitions correspond to data transition.
18				Not used
19	SCA	140	Sec. Request to Send	Request to send on a secondary channel.
20	CD	108.2	Data Terminal Ready	This circuit is positive when the DTE is ready to originate or answer a call in dial up operation.
21	SQ	110	Signal Quality Indicator	Signals on this circuit are used to indicate the probability of an error in the received data. A positive level indicates good signal quality while a negative level indicates poor signal quality.
22	CE	125	Ring Indicator	In direct dial operation, this circuit is positive in response to an incoming ring signal.
23	CH	111	Data Rate Select	Supplies a data rate control to select Primary or Fallback data rate.
24	DA	113	External Transmit Clock	A serial data rate clock input from the data source. Positive clock transitions correspond to data transitions.
25				Not used

Table B-2. Digital Interface Signal Descriptions (232D)

Pin No.	EIA-232D	CCITT	Signal Name	Description
1		101	Shield	No connection
2	BA	103	Transmit Data	Serial digital data (to be modulated) from a data terminal or other digital data source. It must be accompanied by a transmit clock (pin 15) or by an external data rate clock (pin 24). Data transitions should occur on positive-going transitions at clock. (Synchronous modems only.)
3	BB	104	Received Data	Serial digital data at the output of the modem receiver. The data is accompanied by an internal data rate clock (pin 17) whose positive-going transitions occur on the data transition. (Synchronous modems only.)
4	CA	105	Request to Send	A positive level to the modem when data transmission is desired.
5	CB	106	Clear to Send	A positive level from the modem after receipt of Request to Send and when the modem is ready to transmit.
6	CC	107	Data Set Ready	A positive level from the modem when power is on and it is ready to operate. In

Digital Interface Descriptions

Table B-2. Digital Interface Signal Descriptions (232D)

Pin No.	EIA-232D	CCITT	Signal Name	Description
				dial-up operation, the modem must be off-hook to give a high DSR signal.
7	AB	102	Signal Ground or Common Return	Common signal and DC power ground.
8	CF	109	Received Line Signal Detector	A positive level from the modem indicating the presence of a receive signal (carrier detect).
9			+12 volts	+12 voltage reference
10			-12 volts	-12 voltage reference
11	CG	110	Signal Quality Indicator	Signals on this circuit are used to indicate the probability of an error in the receive data. A positive level indicates good signal quality while a negative level indicates poor signal quality.
12			Not used	
15		114	Transmit Clock (DCE)	A transmit data clock output for use by an external data source. Positive clock transitions correspond to data transitions
16			Not used	
17	DD	115	Receive Clock	A receive data rate clock output for use by the external data sink. Positive clock transitions correspond to data transition.
18		141	Local Loopback (Loop 3) Control	A positive level will cause the modem to go into a local analog loop, when strap enabled.
20	CD	108.2	Data Terminal Ready	This circuit is positive when the DTE is ready to originate or answer a call in dial up operation. DTR must always be active (high) in 2-wire private line operation. Cycling DTR causes retraining.
21		140	Remote Digital Loopback	A positive level will cause a digital loopback at a remote modem, when strap enabled.
22	CE	125	Ring Indicator	In a direct dial operation, this circuit is positive in response to an incoming ring signal.
23	CH	111	Data Rate Select	Supplies a data rate control to select Primary or Fallback data rate.
24	DA	113	External Transmit Clock	A serial data rate clock input from the data source. Positive clock transitions correspond to data transitions
25		142	Test Mode	Indicates when the modem is in a test mode.

Appendix C

Telephone Line Cables

Table C-1 lists the functions of the modular jacks on the back panel of the Modem Rack . The figures that follow Table C-1 show typical telephone-line cable configurations. The last two figures show DDS cable configurations.

Table C-1. Modular Jack Pin Functions

TELCO Jack			TELSET/LL Jack	
Pin		Function	Pin	Function
1	R	Xmit pair of DDS modems. Not used on other type modems	1	Xmit pair (Dial backup modems only)
2	T		2	
3	R1/MI	Receive ring for leased line modems. Mode indicator for dialup modems.	3	Not used
4	R	Ring – dial or leased	4	Not used
5	T	Tip – dial or leased	5	Not used
6	T1/ MIC	Receive tip for leased line modems. Mode indicator common for dialup modems	6	Not used
7	PR	Programmable resistor connections for dial network modems.	7	Rec pair (Dial backup modems only)
8	PC		8	
7	T1	Rec pair for DOS type modems.		
8	R1			

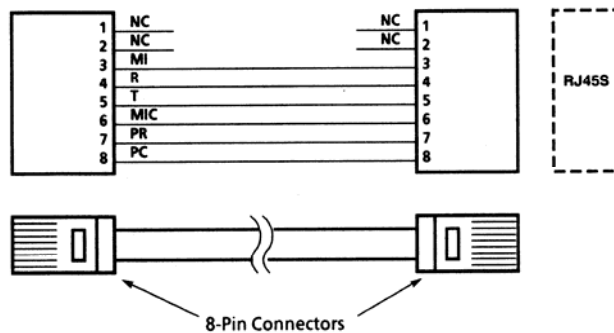

Figure C-1. Programmable Cable

Telephone Line Cables

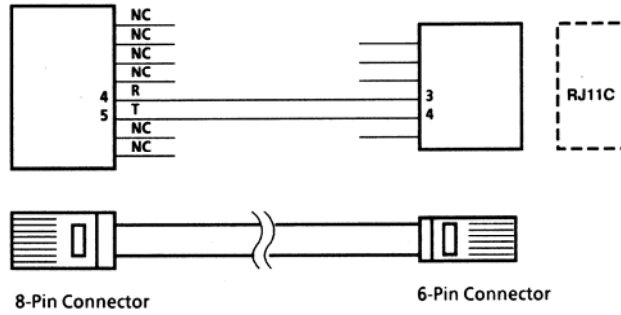

Figure C-2. Permissive Cable

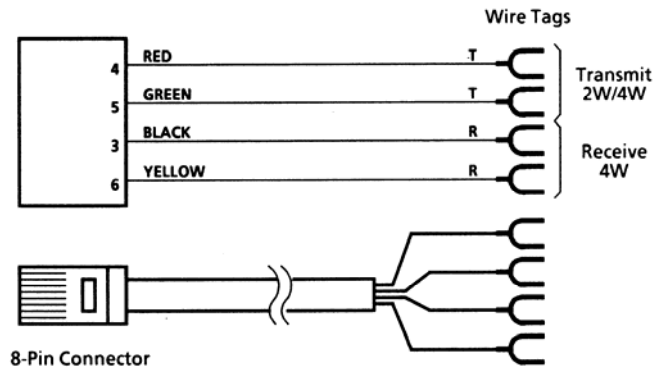

Figure C-3. Leased Line Cable

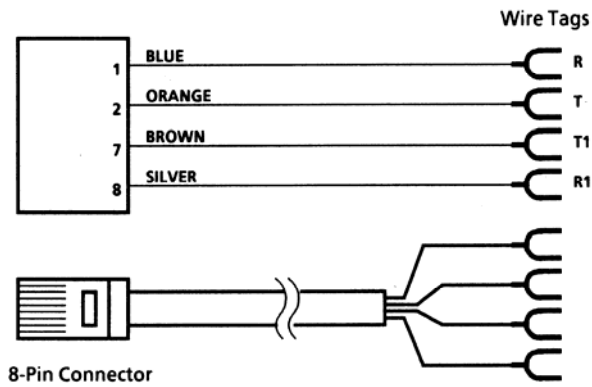

Figure C-4. Example 1: DDS Cable
(cable is also used for dial backup-type modems)

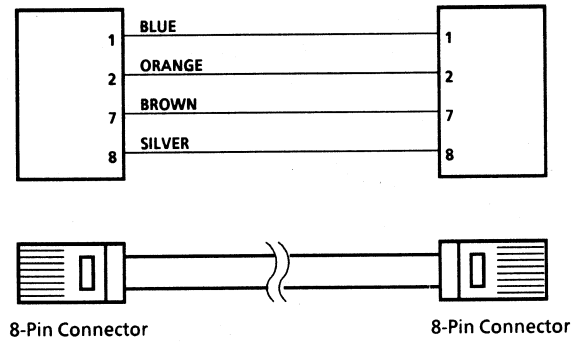

Figure C-5. Example 2: DDS Cable
(cable is also used for dial backup-type modems)

Warranty

Synxcom warrants that equipment manufactured and sold by us is free from defects in material and workmanship. Under this warranty, our obligation is limited to repairing or replacing any equipment or parts (not already carrying a separate warranty of their supplier) proved to be defective by our inspection within two years after sale to their original purchaser. This warranty shall not apply to equipment or parts thereof which are normally consumed in operation, or to any equipment which shall have been repaired or altered outside our plant in any way, so as to, in the judgment of Synxcom, affect its stability or reliability, nor which has been operated in a manner exceeding its specifications, nor which has been altered, defaced, or has the serial number removed. Synxcom does not assume any liability for consequential damages and, in any event, our liability shall not exceed the original purchase price.

The foregoing constitutes the sole and exclusive remedy of the Buyer and exclusive liability of Synxcom AND IS IN LIEU OF ANY AND ALL OTHER WARRANTIES EXPRESSED OR IMPLIED OR STATUTORY AS TO THE MERCHANTABILITY, FITNESS FOR PURPOSE SOLD, DESCRIPTION, QUALITY, PRODUCTIVENESS OR ANY OTHER MATTER. Without limiting the foregoing, in no event shall Synxcom be liable for the loss of use or profit or other collateral, special or consequential damages.

Technical Supports

For the technical support of our customers, please dial (949) 677-6204 between 8:00 a.m. and 5:00 p.m. Pacific Time, Monday through Friday. Do not return any item without first calling this number to receive service or technical instructions. Please feel free to use this number for technical information, application information, and modem/data communication fault isolation.

Return Merchandise Authorization (RMA) Procedure

Before returning any Synxcom product, an RMA number must be obtained. Before asking for an RMA number, ascertain that the product was purchased from Synxcom. If you bought the product from a Distributor or Systems Integrator, the product should be returned to that vendor.

The most convenient method to obtain an RMA number for a product purchased from Synxcom is to send an email to support@Synxcom.com.

Information required must include:

- ❖ Your company name and address
- ❖ The actual address we would use to return the product to you. Please include any Mail Stop or specific delivery information. City, state, and zip code are all required.
- ❖ Your phone and FAX numbers. Your email address.

If the above information is on your letterhead, that format is acceptable.

For each item you wish to return, please list:

- ❖ The product model number, usually found on the serial number tag.

Telephone Line Cables

- ❖ The serial number for each item you wish to return.
- ❖ A description of the problem you are encountering.
- ❖ The cause of the problem (if known).

A product support specialist may call to verify that the product is properly installed or may ask you to perform tests to insure that the product has actually failed.

After review of the problem, an RMA number will be assigned, you will be notified by email or FAX.

The product must be properly packed and returned to:

Synxcom
10 Lee
Irvine, CA 92620

The RMA number must be legibly displayed on the shipping carton.

No RMAs will be issued without a product review, Synxcom will not be responsible for any product returned without an RMA number.

If you think the product may be out of warranty, include a method of payment for repairs, either a Purchase Order number, or Credit card number, Card Holder Name, Date of Expiration on the RMA request. Repairs currently require 5 – 10 working days, and are returned UPS ground.